

Micro Dry Pump

MU Series

/ For Tool Mount /

The world smallest and least power consumption.
The pump can be integrated into any equipment easily.



- Kashiyama ultimate space save design has realized the pumping speed of 1660l/min with the small foot print 230 mm x 450 mm.
- The MU series are perfect for load locks, clean exhaust for transfer rooms and light process application of semiconductor manufacturing.

Specification Table

Specification \ Model	MU100	MU300
Maximum Pumping Speed (L/min)	1,660	5,000
Ultimate Pressure (Pa)	1.5	0.5
Maximum Inlet Pressure (Pa)	Atmospheric pressure	
Electric Power Capacity(kW)	2.2	2.2+2.2
Power in normal operation (kW)	0.7	0.9
Inlet Flange	NW50	
Outlet Flange	NW25	
Weight(Approx.) (kg)	60	100

Pump Schematic (MU100)

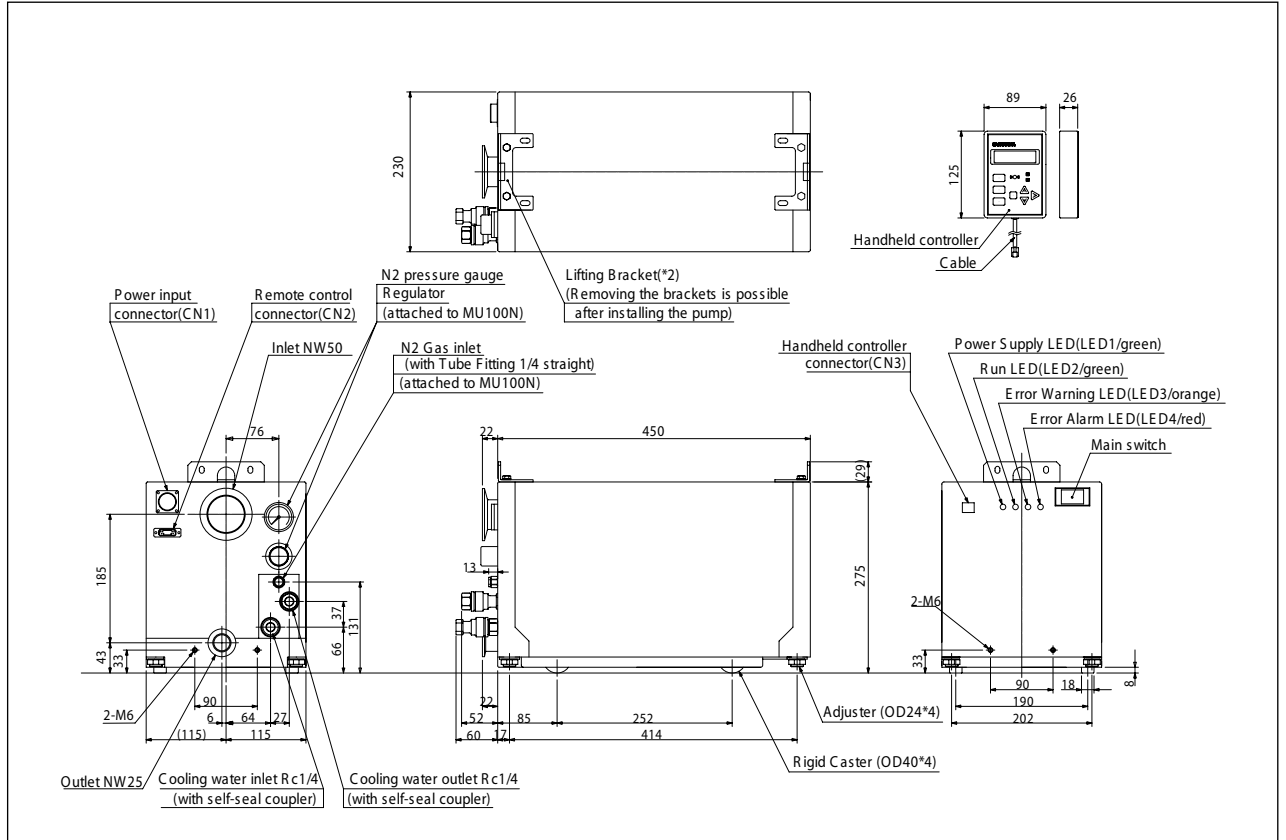

Pump Schematic (MU300)

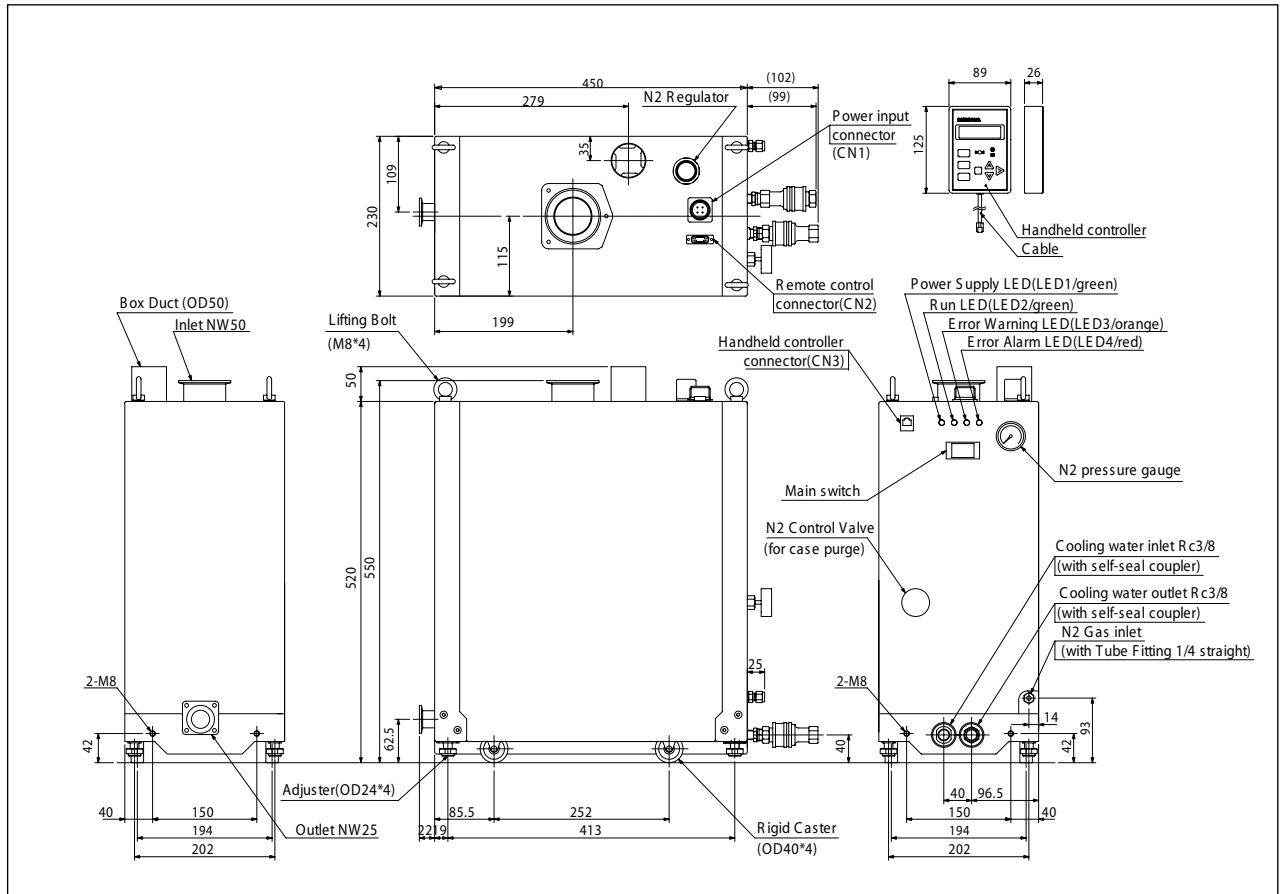

Note 1) Because we are constantly working to improve performance and upgrade our products, specifications and diagrammatic representations in this catalog may change without notice.
 Note 2) Products displayed in this catalog must be approved for export in accordance with the Foreign Exchange and Foreign Trade Control Act. Before placing an export order, please contact our Business Department.

- Dry vacuum Pump
- Mechanical Booster Pump
- Air Discharge System

MICRO DRY PUMP MU SERIES