

High Throughput Dry Pump

SDL Series

HIGH THROUGHPUT DRY PUMP SDL SERIES

Higher pumping speed.
 Support larger diameter wafer, larger FPD substrate and Solar applications.
 Higher pumping speed minimizes the tact time for large load lock chamber.



- Maximized the pumping speed in the atmospheric side to achieve higher throughput.
- The combination with large booster pump allows higher pumping speed up to 55,000L/min.
- Applicable for clean processes.

Specification Table

Specification	Model	SD220L	SDL25K	SDL40K	SDL60K
Maximum Pumping Speed (L/min)		3,100	25,000	40,000	55,000
(Upper 50Hz / Lower 60Hz)		3,700			
Ultimate Pressure (Pa) 50/60Hz		4/3	0.5		
Maximum Inlet Pressure (Pa)		Atmospheric pressure			
Inlet Flange		NW50	NW100		NW160
Outlet Flange		NW40	NW50		
Weight(Approx.) (kg)		450	620	750	910
Electric Power Supply		3 phase AC200 50/60Hz AC220V 60Hz	3 phase AC200-220V 50/60Hz		
Power in normal operation (kW)		5.0	6.9	7.0	7.4
Electric Power Capacity (kVA)		8.3	17.0	23.6	28.1
Cooling Water Supply		5L/min and over	6L/min and over		
Purge N2 Gas Supply		0-50SLM			

Pumping Curve(SP)

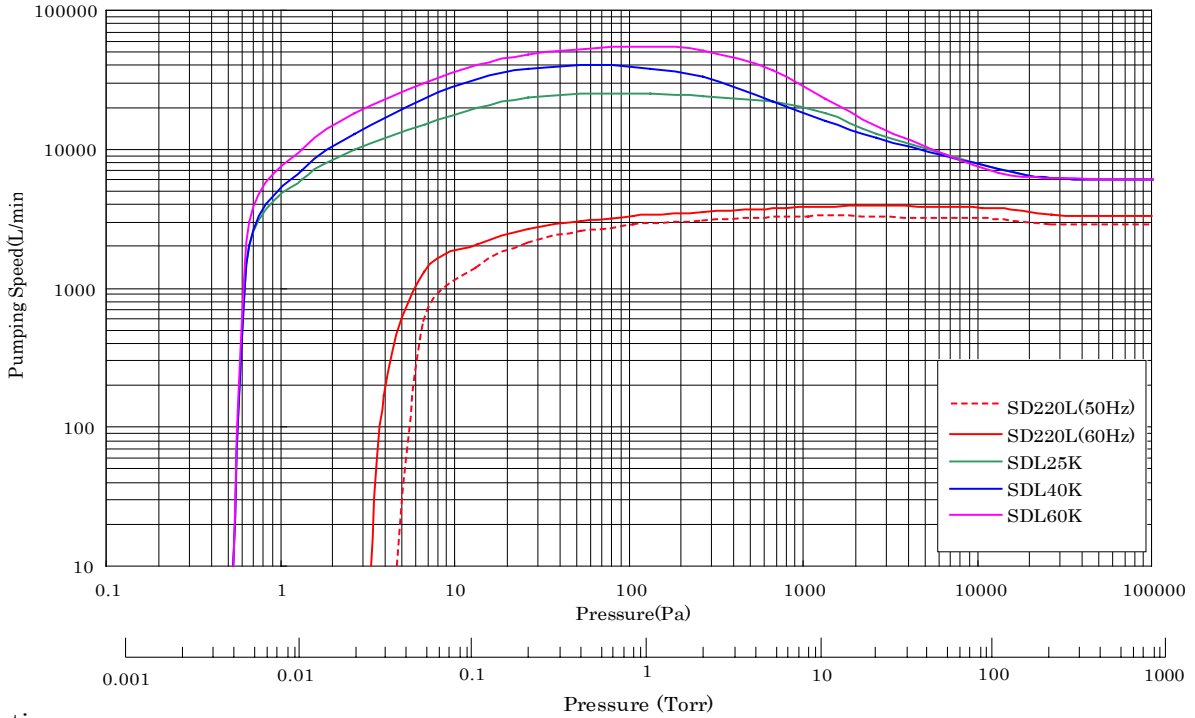

Pump Schematics

SD220L

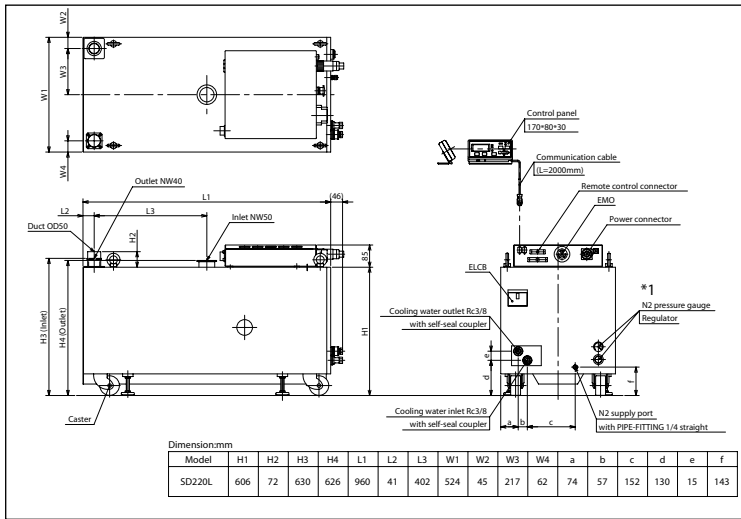

SDL25K

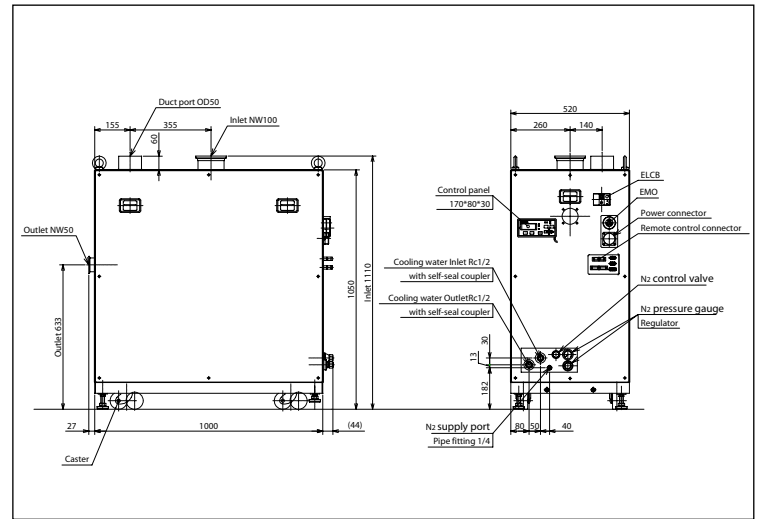

SDL40K

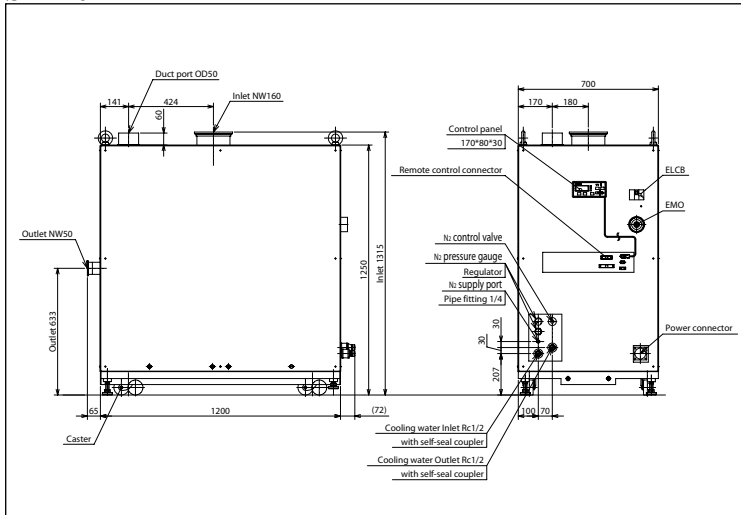

SDL60K

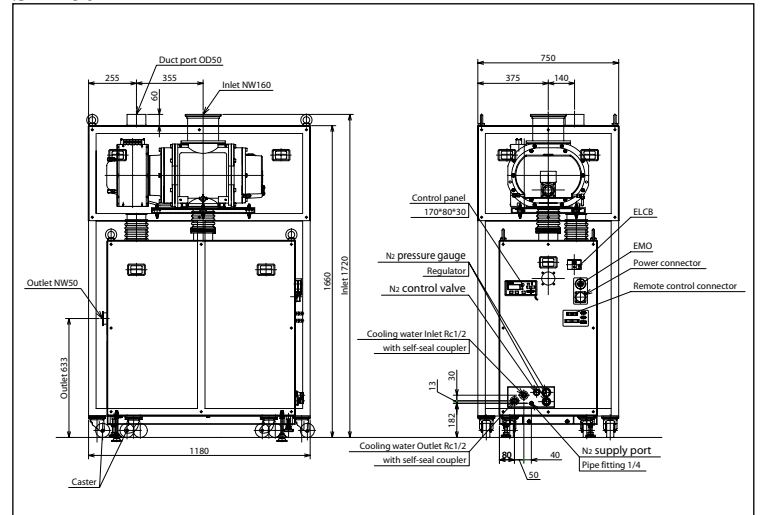

Note 1) Because we are constantly working to improve performance and upgrade our products, specifications and diagrammatic representations in this catalog may change without notice.
 Note 2) Products displayed in this catalog must be approved for export in accordance with the Foreign Exchange and Foreign Trade Control Act. Before placing an export order, please contact our Business Department.

- Dry vacuum Pump
- Mechanical Booster Pump
- Air Discharge System

Kashiyama-USA
 URL: www.kashiyama.com/us/
 mail address for inquiries:
sales@kashiyama.com